

Réf: MSHE-112M 2,2KW 6P B5

## B5

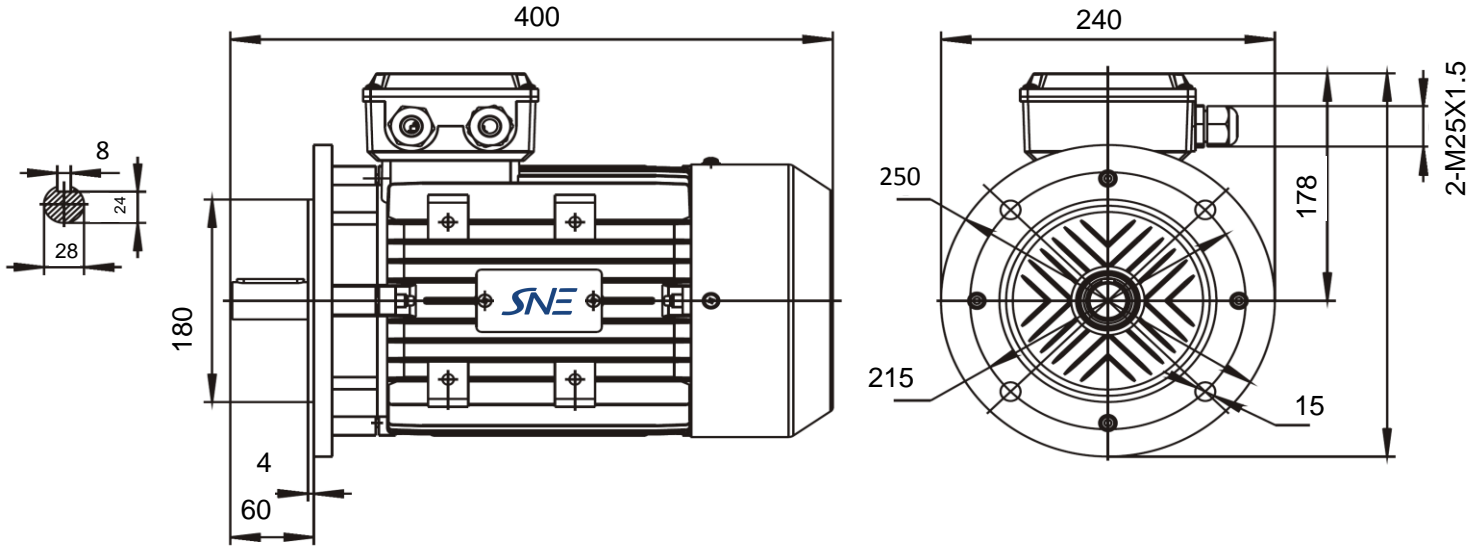

Specification	<b>IEC 60034-1</b>		
Manufacturer	<b>SNE</b>		
Motor type	<b>MSHE112M</b>		
Rated power	<b>2,2</b> kW	<b>S1</b>	duty
Speed	<b>960</b> r.p.m		
Voltage	<b>230/400</b> V		
Frequency	<b>50</b> Hz		
Connection			
230 V	<b>9,49</b> A		
400 V	<b>5,45</b> A		
Enclosure	<b>IP 55</b>		
Insulation Class	<b>F/B</b>		
Max. coolant temp.	<b>40°C</b>		
Max. altitude	<b>1 000</b> mtr,	above sea level	
Comment			
Cable entries			
Feature	<b>Aluminium</b>		
Weight	<b>35,2</b> kg		

Efficiency class				
Load data	100%	75%	50%	
Efficiency	<b>82,0</b>	<b>82,1</b>	<b>81,5</b>	%
Power factor	<b>0,71</b>	<b>0,59</b>	<b>0,45</b>	
Sound pressure level (1m)				<b>65,0</b> dB(A)
Resistance R <sub>20</sub> (open)				Ω
Resistance R <sub>20</sub>				Ω
Locked rotor current Is/Ir				<b>7,5</b> A
Locked rotor torque Ms/Mr				<b>2,5</b> Nm
Torque				<b>22,0</b> Nm
Torque max				<b>3</b> Nm
Rotor inertia	J=GD <sup>2</sup> /4			Kgm <sup>2</sup>

Bearing DE	<b>6306 2RS/C3</b>
Bearing NDE	<b>6306 2RS/C3</b>