

Réf: MSHE-160M1 11KW 2P B5

## B5

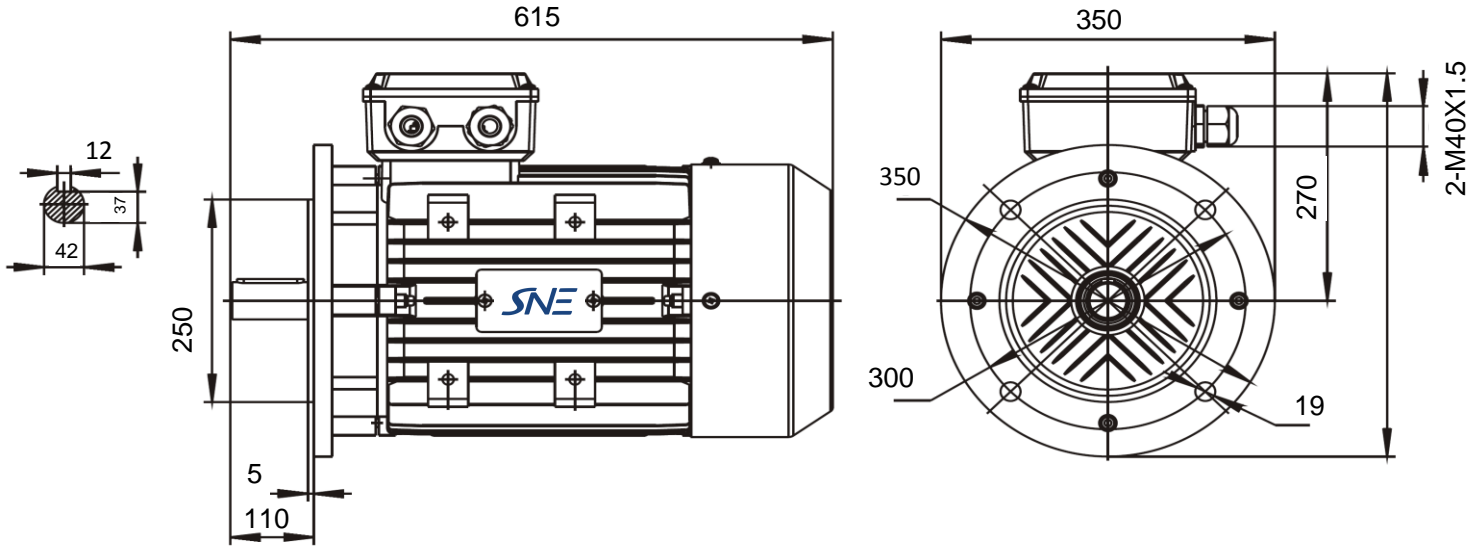

Specification	<b>IEC 60034-1</b>		
Manufacturer	<b>SNE</b>		
Motor type	<b>IE2MS160M1-2</b>		
Rated power	<b>11</b> kW	<b>S1</b>	duty
Speed	<b>2935</b> r.p.m		
Voltage	<b>400/690</b> V		
Frequency	<b>50</b> Hz		
Connection			
230 V	<b>34,6</b> A		
400 V	<b>20</b> A		
690 V	<b>11,5</b> A		
Enclosure	<b>IP 55</b>		
Insulation Class	<b>F/B</b>		
Max. coolant temp.	<b>40°C</b>		
Max. altitude	<b>1 000</b> mtr,	above sea level	
Comment			
Cable entries			
Feature	<b>Aluminium</b>		
Weight	<b>74</b> kg		

Efficiency class				
Load data	100%	75%	50%	
Efficiency	<b>89,4</b>	<b>89,6</b>	<b>88,3</b>	%
Power factor	<b>0,89</b>	<b>0,85</b>	<b>0,82</b>	
Sound pressure level (1m)			<b>81,0</b>	dB(A)
Resistance R <sub>20</sub> (open)				Ω
Resistance R <sub>20</sub>				Ω
Locked rotor current Is/Ir			<b>7,5</b>	A
Locked rotor torque Ms/Mr			<b>2,2</b>	Nm
Torque			<b>35,7</b>	Nm
Torque max			<b>2,3</b>	Nm
Rotor inertia	J=GD <sup>2</sup> /4			Kgm <sup>2</sup>
Bearing DE			<b>6209 2RS/C3</b>	
Bearing NDE			<b>6209 2RS/C3</b>	