

Réf: MSHE-902 1,5KW 2P B3

B3

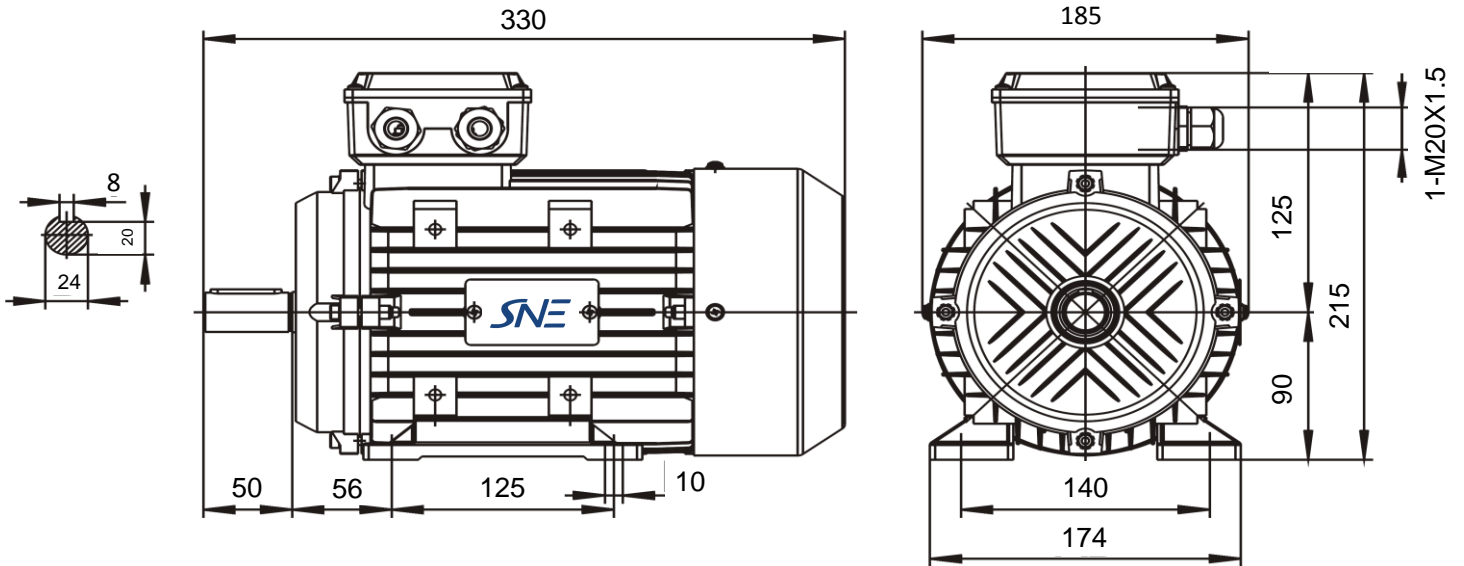

Specification	IEC 60034-1		
Manufacturer	SNE		
Motor type	IE2MA90S2		
Rated power	1,5 kW	S1	duty
Speed	2880 r.p.m		
Voltage	230/400 V		
Frequency	50 Hz		
Connection			
230 V	5,47 A		
400 V	3,14 A		
Enclosure	IP 55		
Insulation Class	F/B		
Max. coolant temp.	40°C		
Max. altitude	1 000 mtr,		above sea level
Comment			
Cable entries			
Feature	Aluminium		
Weight	14,6 kg		

Efficiency class				
Load data	100%	75%	50%	
Efficiency	82,0	82,1	81,7	%
Power factor	0,84	0,78	0,67	
Sound pressure level (1m)			67,0	dB(A)
Resistance R ₂₀ (open)				Ω
Resistance R ₂₀				Ω
Locked rotor current I _s /I _r			7,1	A
Locked rotor torque M _s /M _r			2,7	Nm
Torque			5,0	Nm
Torque max			3,5	Nm
Rotor inertia	J=GD ² /4		0,0055	Kgm ²
Bearing DE			6205 2RS/C3	
Bearing NDE			6204 2RS/C3	