

Réf: YE2-160L-2P 18,5KW 2P B3

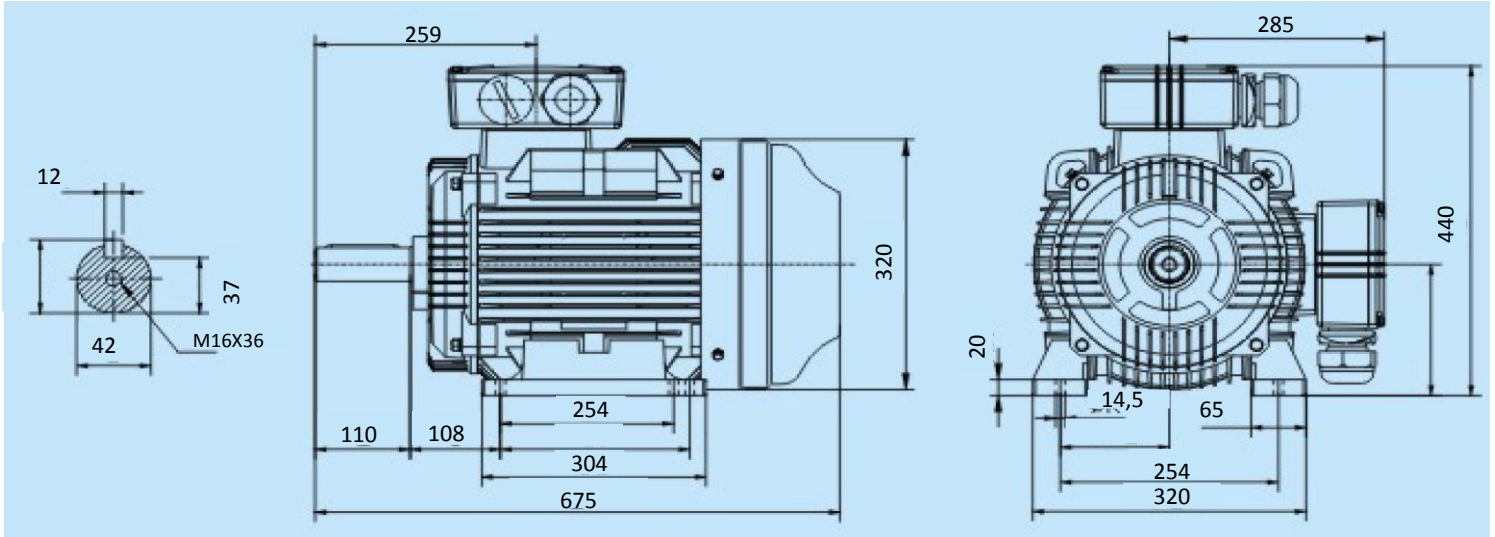

Specification	IEC 60034-1	Efficiency class	
Manufacturer	SNE	Load data	100%
Motor type	YE2-160L-2P	Efficiency	90,9
Rated power	18,5 kW	Power factor	0,89
Speed	2940 r.p.m		
Voltage	400/690 V	Sound pressure level (1m)	81,0 dB(A)
Frequency	50 Hz	Resistance R ₂₀ (open)	Ω
Connection	Δ / Y	Resistance R ₂₀	Ω
400 v	33 A	Locked rotor current Is/Ir	8,1
690 v	19,1 A	Locked rotor torque Ms/Mr	2,2
Enclosure	IP 55	Torque	60,1
Insulation Class	F/B	Torque max	2,3
Max. coolant temp.	40°C		
Max. altitude	1 000 mtr, above sea level	Rotor inertia J=GD ² /4	0,0648 Kgm ²
Comment			
Cable entries	2-M40X1,5 mm		
Terminal box	200X160X80 mm		
Feature	Cast-iron	Bearing DE	6309/C3
Weight	134 kg	Bearing NDE	6309/C3