

Réf: YX3-200L-4P 30KW 4P B3

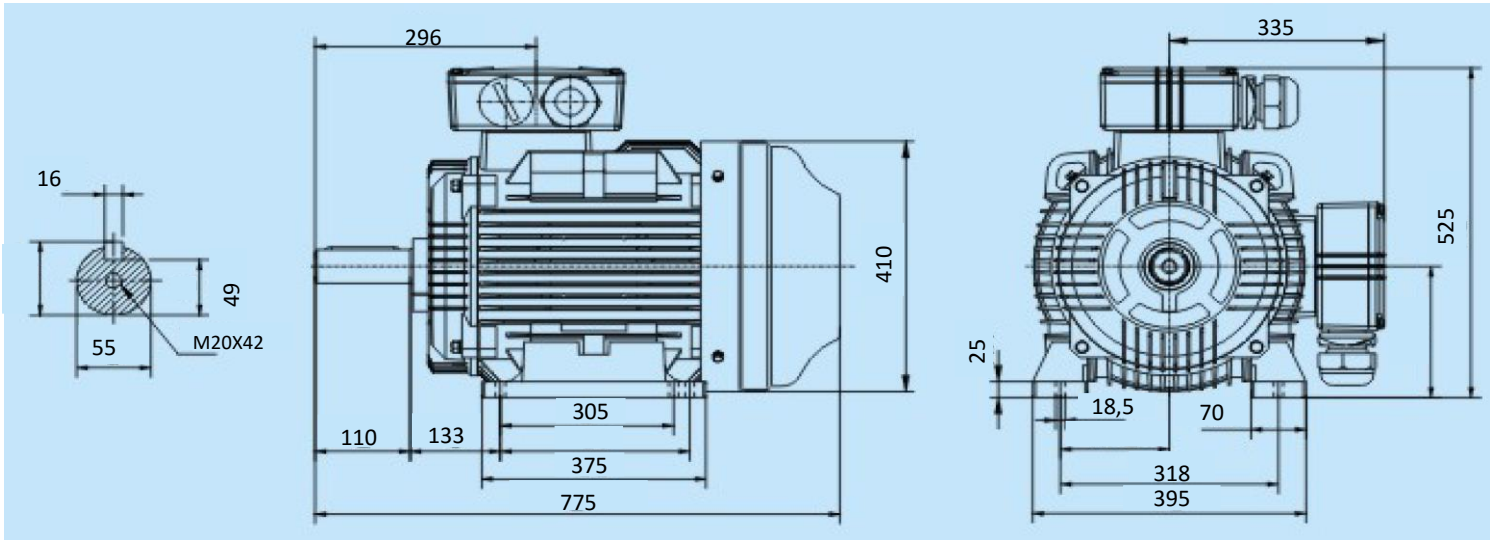

Specification	IEC 60034-1	Efficiency class	
Manufacturer	SNE	Load data	100%
Motor type	YX3-200L-4P	Efficiency	93,6 %
Rated power	30 kW S1 duty	Power factor	0,86
Speed	1475 r.p.m	Sound pressure level (1m)	63,0 dB(A)
Voltage	400/690 V	Resistance R ₂₀ (open)	Ω
Frequency	50 Hz	Resistance R ₂₀	Ω
Connection		Locked current Rated Current	7,3
400 V	53,8 A	Locked current Rated Torque	2,0
690 V	31,1 A	Torque	194,24
Enclosure	IP 55	Torque max / Rated Torque	2,3
Insulation Class	F/B	Rotor inertia J=GD ² /4	0,3631 Kg ^m ²
Max. coolant temp.	40°C	Bearing DE	6312 /C3
Max. altitude	1 000 mtr, above sea level	Bearing NDE	6312 /C3
Comment			
Cable entries	2-M50X1,5 mm		
Terminal box	250X200X92 mm		
Feature	Cast-iron		
Weight	290 kg		