

Réf: YX3-200L1-2P 30KW 2P B3

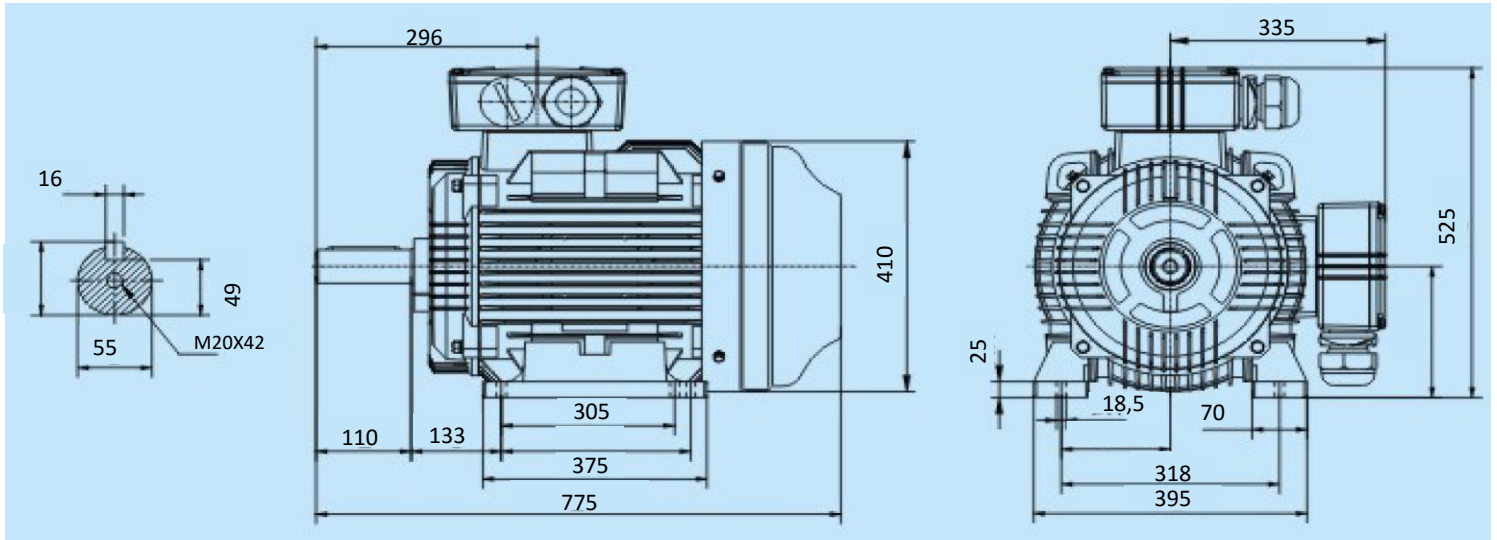

Specification	<b>IEC 60034-1</b>	Efficiency class	
Manufacturer	<b>SNE</b>	Load data	100%
Motor type	<b>YX3-200L1-2P</b>	Efficiency	<b>93,3</b> %
Rated power	<b>30</b> kW <b>S1</b> duty	Power factor	<b>0,89</b>
Speed	<b>2965</b> r.p.m	Sound pressure level (1m)	<b>72,0</b> dB(A)
Voltage	<b>400/690</b> V	Resistance R <sub>20</sub> (open)	Ω
Frequency	<b>50</b> Hz	Resistance R <sub>20</sub>	Ω
Connection		Locked current Rated Current	<b>7,6</b>
400 V	<b>52,2</b> A	Locked current Rated Torque	<b>2,0</b>
690 V	<b>30,1</b> A	Torque	<b>96,63</b>
Enclosure	<b>IP 55</b>	Torque max / Rated Torque	<b>2,3</b>
Insulation Class	<b>F/B</b>	Rotor inertia J=GD <sup>2</sup> /4	<b>0,1649</b> Kg <sup>m</sup> <sup>2</sup>
Max. coolant temp.	<b>40°C</b>	Bearing DE	<b>6312C3</b>
Max. altitude	<b>1 000</b> mtr, above sea level	Bearing NDE	<b>6312C3</b>
Comment			
Cable entries	<b>2-M50X1,5</b> mm		
Terminal box	<b>250X200X92</b> mm		
Feature	<b>Cast-iron</b>		
Weight	<b>246</b> kg		